

Flat Pattern view
SCALE: 1:10

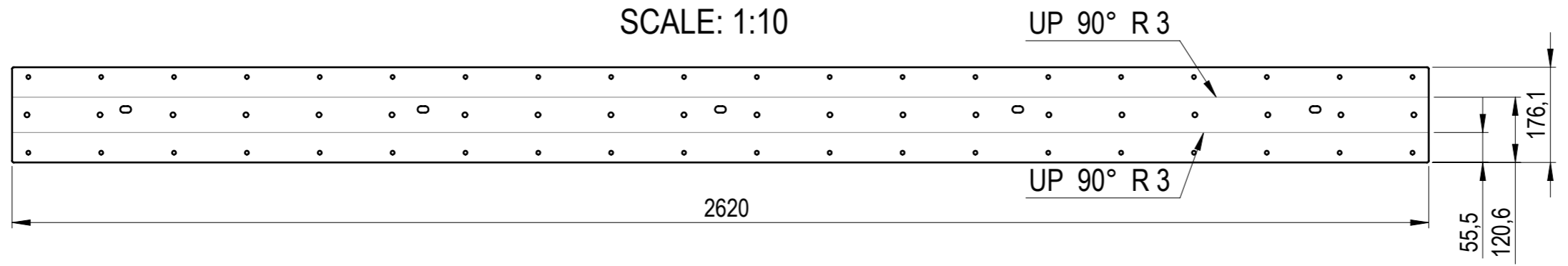

Other dimensions from DXF file

SHEET METAL INFORMATION	
Length, mm	2620
Width, mm	176.1
Thickness, mm	3
Inside Bend Radius, mm	3
K-Factor	0.5
No. of Bends	2

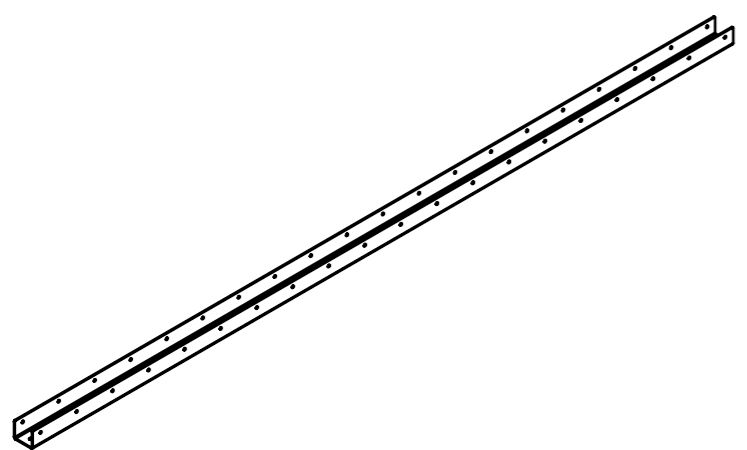

	MATERIAL	WEIGHT	DEBURR AND BREAK SHARP EDGES		REVISION	DATE
	S355	10.708 Kg	DO NOT SCALE DRAWING			09.06.2025
	SURFACE PROTECTION	MACHINING	THERMAL CUTTING	WELDING	SCALE	FORMAT
	HDG EN ISO 1461	ISO 2768 mK	ISO 9013 441	ISO 13920 BF	1:10	A3
	NAME	SIGNATURE	PART NO.			
Designed by	D. Dislers		105-30130-01			
Drawn by	D. Dislers		DESCRIPTION			
Technical ref.			Bent U-profile			SHEET 1/1